

N10001ST Series
Mini Waterproof Electromagnetic Lock



● Features

- Low maintenance with high reliability
- Holding force up to 600 lbs (272 Kg)
- Suitable for harsh environment
- Stainless steel vandal resistant casing
- Single or dual voltage input
- Anti-Residual Magnetism (ARM) function
- New style mounting plate with increased immobility

● Statement

N10001ST is designed for surface mount on outswing doors. It achieves waterproof rating IPX7 and is suitable for outdoor applications. The retention of lock is strong due to deeper screw holes in the mounting plate. N10001STR comes with magnetic bond sensor indicating locked and unlocked status.

● Specification

- Operating Voltage: Single Voltage: 12 or 24 VDC
Dual Voltage: 12/24 VDC
- Current Draw:
Single Voltage: 280mA/12VDC, 250mA/24VDC
Dual Voltage: 500mA/12VDC, 250mA/24VDC
(at temperature 20°C)
- Bond sensor output (N10001STR/M):
SPDT rated: 0.5A/20VDC
- Operating temperature: -10~55°C (14~131°F)
- Humidity: 0~95% non-condensing
- Holding force: Up to 600lbs (272Kg)
- Dimensions:
Magnet: (L)218, (W) 44, (D) 27.5mm
Armature plate: (L) 185, (W) 38, (D) 12mm
- Special finishes for magnet and armature plate:
Zinc plated
- Epoxy potting compound: E87252(S), UL94V-0
- Weight(Approx.):1.5Kg

● Dimensions

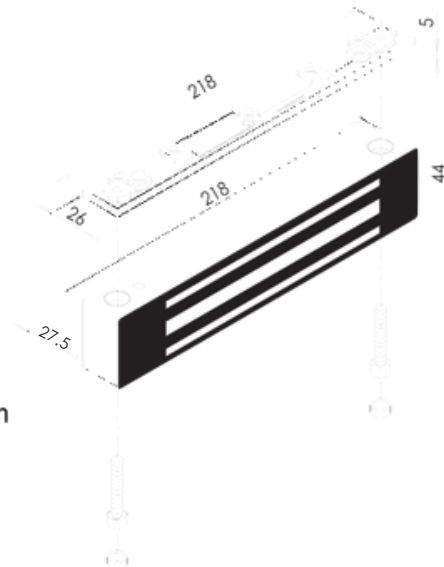

Unit: mm

● New style mounting plate

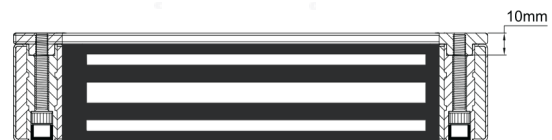

10mm thickness to increase immobility and strength.



● **Optional Brackets**

A appropriate bracket fully complements the magnetic lock. Brackets are selected according to the direction of door swing, the thickness of door frame and the materials of the doors.

Outswing doors: L-brackets are recommended for use on doors with narrow frames

When the door frame thickness (marked 'A') is less than 42 mm it is highly recommended to use the L-N10001ST bracket to enable installation.

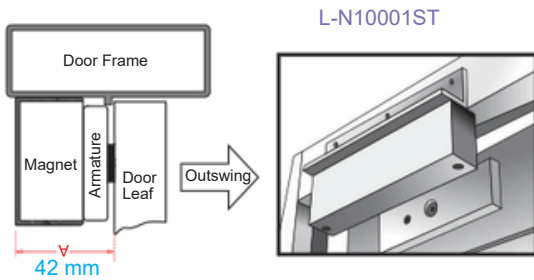

The mounting plate should be screwed to the L-bracket prior to installing the L-bracket. After the L-bracket is installed the magnet can then be screwed to the L-bracket.

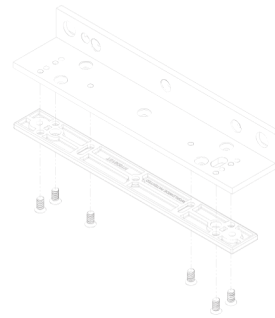

In swing doors: LZ-brackets are recommended for doors that open inwards.

Special nut that mount on L-bracket can help to increase the strength and immobility.

LZ-N10001ST

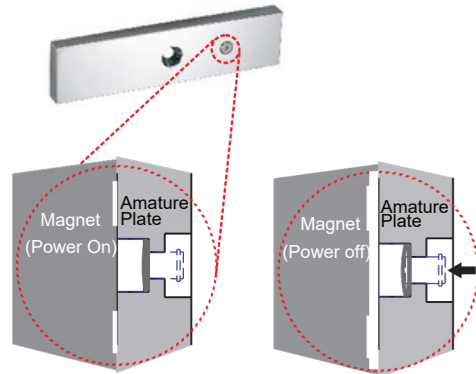
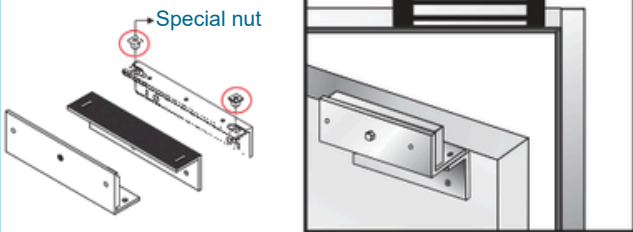

Anti-residual statement

Our electromagnetic locks feature Anti-Residual Magnetism (ARM) which ensures the door can be opened without any resistance from leftover magnetism imparted to the armature plate.

Out swinging full frameless glass doors: the U-shape bracket, UBK-013 is recommended for use on full frameless glass doors with thickness of between 10 and 12 mm.

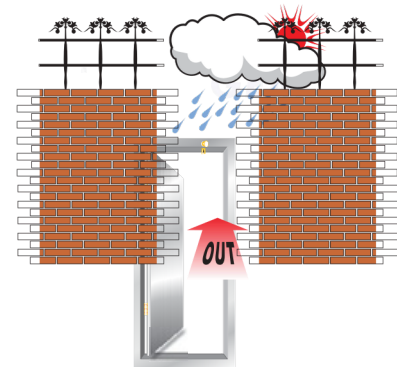
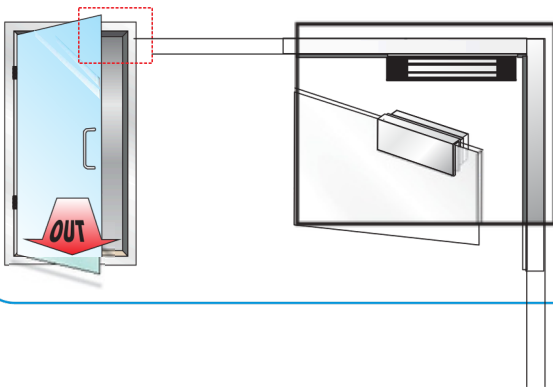

This series of Waterproof Magnetic Lock is protected by epoxy potting compound. Also, GEM Waterproof Series Magnetic Locks have been proved to withstand water with the test procedures of IPX7, IPX8 by a trusted third party. Therefore users need not worry that the lock will rust or spark, if the lock is in outdoor applications and installed in confined space where inflammable gases are stored.