



Explosion-proof Wall Mount Door Holder



Model: EPDH-611-EX



Introduction

1. The Factory default voltage is 12/24VDC Optional
The door holders are designed for use with self-closing fire and smoke barrier doors and keep the fireproof door open.
2. The IP rating is Ip67 and holding force is 150kg. It can be used in navigation, ships, and humid environments.

Specifications

- Size: 97.5Lx75Wx40H(mm)
- Suction plate size: Φ 74.5x41 (mm)
- Operating Voltage: 12/24VDC Optional
- Operating Current: 0.13A
- Holding Force: 150kg
- Maximum Power: 3W
- IP Rating: IP67
- Certificate numbe: ECM 23 ATEX-B DN89
- ATEX: II 1G Ex ib IIC T6 Gb
II 2D Ex ib IIIC T85°C /T100°C Db
- Accessory : cable PG9 Water Proof Conduit Pipe
- Product Weight: 1.66kg

Dimension

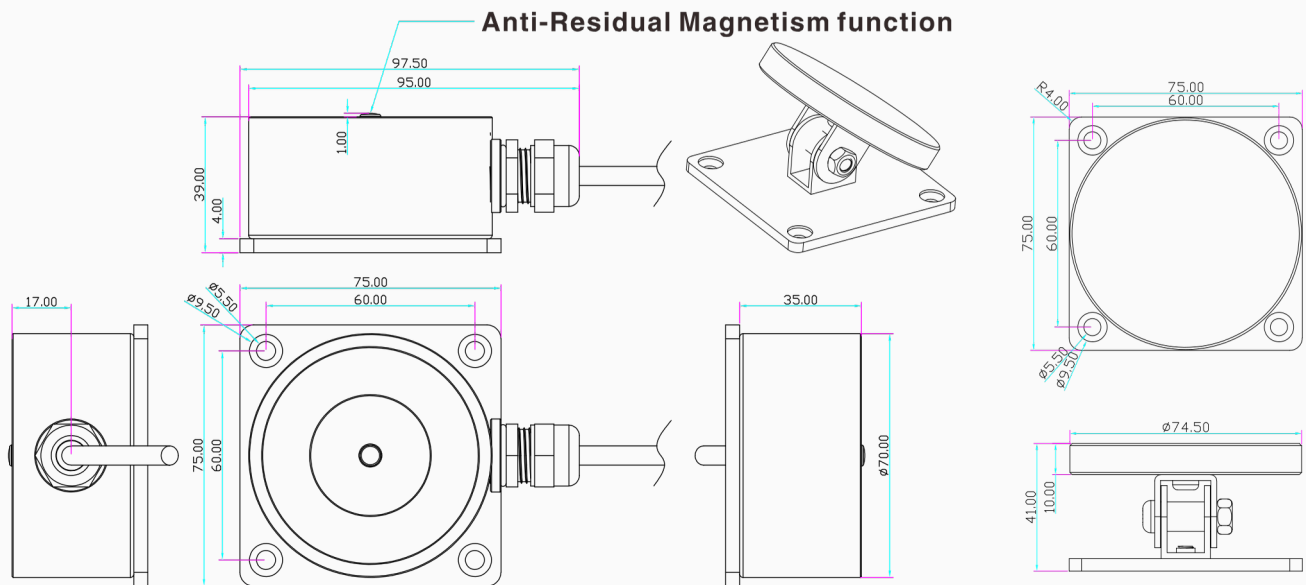

Installation

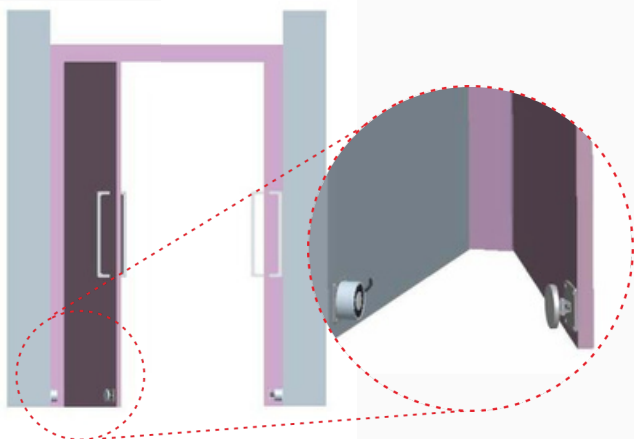

Wiring Instruction

DC 12V



DC 24V

